

NERO



MANUALE D'ISTRUZIONI • OPERATING MANUAL
MANUEL D'INSTRUCTIONS • BETRIEBSANLEITUNG
MANUAL DE INSTRUCCIONES

 **Formula**

Vers. 03

- I** Scarica il manuale del prodotto direttamente dal web:
- GB** Pls. download the products' instruction manual from the website:
- F** Merci de bien vouloir telecharger le manuel d'instructions sur la page:
- D** Bitte laden Sie die Betriebsanleitung vom den folgenden website:
- E** Por favor, descárgate el manual de instrucciones de nuestros productos de la web:
- BG** Моля, изтеглете наръчника на потребителя от следния адрес:
- HR** Molimo download-ajte nstruksijski priručnik sa internetske stranice:
- SLO** Prosimo, da si naložite navodila o uporabi na strani:
- CZ** Stáhněte si prosím návod k použití z této webové stránky:
- DK** Download venligst produktets betjeningsvejledning fra følgende hjemmeside:
- SF** Ole hyvää ja lataa tuotteen käyttöohje seuraavalta sivulta:
- LV** Lūdzu lejupielādējiet instrukciju brošūru no adreses:
- PL** Proszę pobrać instrukcję obsługi produktu ze strony:
- P** Por favor, descarga o manual de instruçōes dos nossos produtos na web:
- SK** Prosím stiahnite si manuál produktov a inštrukcie z web stránky:
- S** Download venligst produktets betjeningsvejledning fra følgende hjemmeside:
- H** Kérem, töltsd le a terméknek használati utasításait a website-ról:
- N** Last ned instruksjonsmanual for dette produktet på vår website:
- NL** Aub. Download de product handleiding van de website:
- CN** 请到网页下载产品使用手册:

<http://rideformula.com>

TORX® è un marchio registrato di CAMCAR / TEXTRON INC. Tutti i marchi appartengono ai rispettivi proprietari.

TORX® is a registered trademark of CAMCAR / TEXTRON INC. All trademarks are the property of their respective owners.

TORX® est une marque déposée de CAMCAR / TEXTRON INC. Toutes les marques appartiennent aux propriétaires respectifs.

TORX® ist ein registriertes Warenzeichen der CAMCAR / TEXTRON INC. Alle Warenzeichen gehören den respektiven Eigentümern an.

TORX® es una marca registrada de CAMCAR / TEXTRON INC. Todas las marcas pertenecen a los respectivos propietarios.

WARNING! BEFORE INSTALLING AND USING THIS NEW FORMULA. PRODUCT IT IS CRITICAL TO YOUR SAFETY THAT YOU READ AND STRICTLY ADHERE TO THE INSTRUCTIONS IN THIS MANUAL. FAILURE TO DO SO COULD CAUSE SERIOUS INJURY AND/OR INVALIDATE YOUR LEGAL RIGHTS. KEEP THIS MANUAL IN A SAFE PLACE FOR FUTURE REFERENCE AS IT CONTAINS INFORMATION CRITICAL TO YOUR SAFETY.

WARNING! DO NOT INSTALL OR DISASSEMBLE THIS FORMULA. PRODUCT ON YOUR OWN!

Always seek the help of a professional mechanic. If you decide to ignore this important warning, keep in mind that you are doing so EXCLUSIVELY at your own risk.

Note: AS WITH ANY MANUAL, THIS ONE MAY BE UPDATED. CONTACT YOUR FORMULA DEALER, OR CHECK OUR WEB SITE, (www.rideformula.com) TO RECEIVE ANY SUCH UPDATES.

This manual contains information for the safe use, proper mounting and maintenance of NERO forks. Following the rules contained in this manual will ensure the safe use and longest life of your NERO forks.

Carefully follow the SAFETY GUIDELINES to assure appropriate use and service of NERO forks.

In this handbook you will find the following safety symbols:



CAUTION: Directs your attention toward unsafe practices, which could result in damage to the equipment or minor injury.



WARNING: Directs your attention toward unsafe practices, which could result in serious injury or death.

It is impossible to anticipate every situation that may occur while riding a bicycle. This manual makes no representation about the safe use of the bicycle under all conditions. There are risks associated with the use of any bicycle that cannot be predicted or avoided. By choosing to ride a bicycle, you assume the responsibility for that risk. Read and understand your bicycle owner's manual before using your bicycle.

GENERAL SAFETY GUIDELINES

- Never put your hands near or inside rotating parts. Protective five-finger gloves that do not reduce sensitivity or your ability to grip should be used during repair.
- Before starting any mounting operations, carefully check for dangerous conditions at the work site. If too dark, use all available light sources and make sure they work properly before starting work.
- All maintenance operations must be carried out solely by personnel authorized by FORMULA.
- Make sure that the Wheel Pin is correctly adjusted. Bounce your bicycle off the ground from about 10cm/4" to check the presence of loose parts.

An incorrectly adjusted wheel pin can cause the wheel to detach.

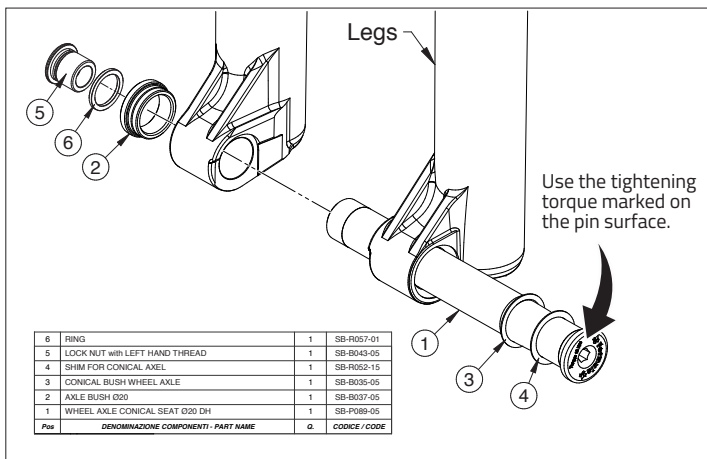

- After inserting the wheel, first screw the wheel pin (1) to 18 Nm, then tighten the safety lock nut (5). The lock nut has a left-hand thread so it is screwed counterclockwise and unscrewed clockwise.
- Before riding, verify that the brakes on your bicycle are installed and adjusted correctly. Improperly installed and adjusted brakes may cause a crash and result in property damage, serious injury, or death.
- Make sure cables and hoses do not impede the steering of the bicycle.
- When using the bicycle in the wet, remember that the grip of the tires on the ground decreases, making it more difficult to control the vehicle. Furthermore, it must be borne in mind that due to the progressive drying of the braking surface during braking, the braking power may vary abruptly, so pay more attention when driving in wet conditions to avoid possible accidents. NERO forks are not designed for use on public roads.
- NERO forks are designed for competitive off-road riding and racing.

NERO FORKS SAFETY GUIDELINES

- The NERO forks produced by FORMULA. are designed exclusively for use on two wheel bicycles. Any other use is to be considered hazardous. FORMULA. shall not be held liable for any consequences from improper use.
- If the fork ever loses oil or makes unusual noises, stop riding and have it inspected by FORMULA. or an authorized dealer. Continuing to use a malfunctioning fork can cause a sudden loss of control, resulting in serious injury or death. Some sounds, such as oil flow, minor clicks, and spring rattle, are considered normal. When in doubt, consult your local FORMULA dealer.
- NERO forks have a crown / steerer . These parts are pressed together through a single precision pressing operation. Replacing any of these parts requires a complete new upper assembly. Never attempt to remove or replace the steerer independently from the crown. NEVER ATTEMPT TO CUT THREADS INTO THE THREADLESS STEERER. Modifying the crown / steerer assembly can cause loss of control of the bicycle and serious injury or death.
- Impact, falls, improper or harsh use of the bicycle may compromise the structural integrity of the forks, significantly reducing their lifespan.
- Have the forks regularly inspected by a qualified mechanic for any cracks, deformation, signs of fatigue or wear. Use of penetrating fluid or other visual enhancers to locate cracks on parts is recommended.
- If inspection reveals any deformation, cracks, signs of impact or stress, no matter how slight, immediately replace the component. Excessively worn components also require immediate replacement.
- The frequency at which inspection is required depends on many factors. Ask a FORMULA. dealer to recommend an inspection and service schedule that is right for you.
- If you weigh more than 90kg/198 lbs be especially careful and have the bike inspected more frequently.
- Parts that have been bent or damaged in an accident, or as the result of impact, must be immediately replaced with genuine FORMULA. replacement parts.
- The user of NERO forks expressly recognizes that there are risks inherent in bicycle riding, including but not limited to failure of a bike component, resulting in an accident, personal injury or death.
- By purchasing and using these NERO forks the user expressly, voluntarily and knowingly accepts and/or assumes these risks, including but not limited to the risk of passive negligence on the part of FORMULA., i.e. hidden, latent or obvious defects and exempts FORMULA. from liability to the fullest extent permitted by law against any resulting damage.
- Carefully read the NERO forks instructions before use.
- Carefully follow the scheduled maintenance program as indicated in the relative paragraph.
- Always use genuine FORMULA. replacement parts.

By purchasing and using these NERO fork, the user expressly, voluntarily and knowingly accepts and/or assumes these risks, including but not limited to the risk of passive negligence on the part of FORMULA., i.e. hidden, latent or obvious defects and exempts FORMULA. from liability to the fullest extent permitted by law against any resulting damage.



ENVIRONMENTAL NOTES

In order to protect the environment, please follow to these simple instructions to correctly dispose of FORMULA. products:

- 1) The packaging does not require special disposal because it is not dangerous in any way; we suggest recycling paper and plastic.
- 2) It is also recommended to recycle the metal parts after use.

For both points mentioned above, it is recommended to dispose of waste following national regulations through specialized waste disposal companies.

Pos	Name
1	Steering tube
2	Upper triple clamp
3	Lower triple clamp
4	Stanchion tube
5	Lower leg
6	Disc brake connection
7	Rebound knob
8	Wheel connection
9	Low speed compression adjustment
10	Spring preload adjustment
11	High speed compression adjustment
12	Upper clamp screws
13	Bottom clamp screws

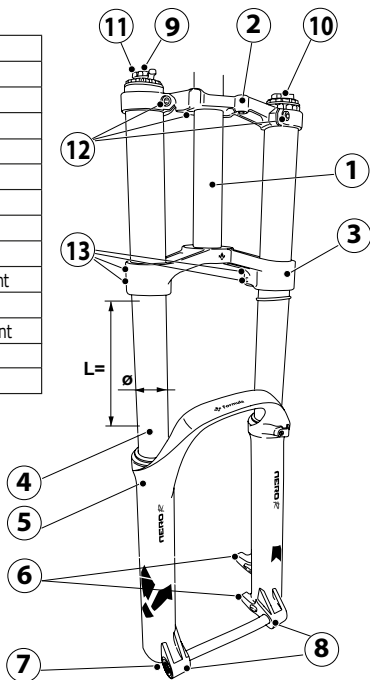

* It is possible to request an upper triple clamp with different height to adapt to frames with a shorter tube

1 TECHNICAL SPECIFICATIONS NERO C

FORKS 27.5"

Fork Travel	Axle To Crown ± 5.0 mm (*)	Tire Size limit
200mm	581	<i>27.5 x 2.50 inch wide Any tire size greater than 2.35 inch wide must be checked with fork fully compressed and have a minimum of 6.0 mm "tire to crown" clearance.</i>

FORKS 29"

Fork Travel	Axle To Crown ± 5.0 mm (*)	Tire Size limit
200mm	593	<i>29 x 2.50 inch wide Any 29 inch tire size greater than 2.35 inch wide must be checked with fork fully compressed and have a minimum of 6.0mm "tire to crown" clearance 27.5 x 3.0 inch wide Any tire size greater than 2.70 inch wide must be checked with fork fully compressed and have a minimum of 6.0 mm "tire to crown" clearance.</i>

* The value for "axle to crown" can be changed removing the pipes from the plates.

⚠ WARNING: Every time the value "axle to crown" is changed, make sure that the distance between the crown and the tire is greater than 6 mm. In addition, make sure that the words "end stroke" on the pipe remains below the lower plate (3).

- Gap Tire / Crown control

It can also be checked by removing the left cap, pushing the fork down and checking that 6mm remains.

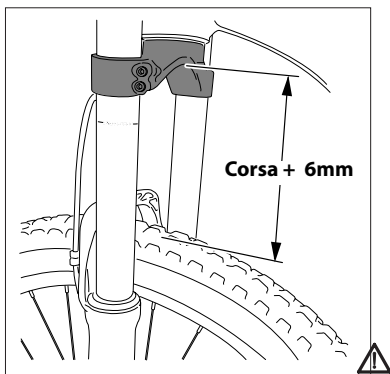

- END STROKE written control

⚠ WARNING: the checks described above must both be done.

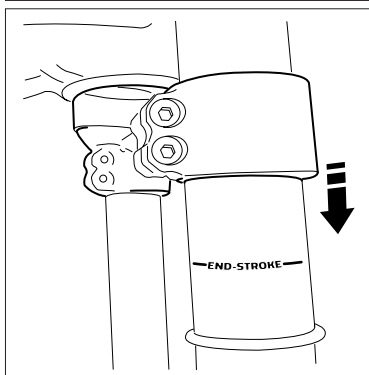

1.1 Triple clamp screws tightening torque

Upper steering triple clamp screws = 6 Nm

Lower steering triple clamp screws = 8 Nm (2 screw per side model).

1.2 Disc brakes

Install disc brakes and torque all fasteners according to manufacturer's specifications. Install, route and check that all cables or hydraulic hoses are securely fastened to the lower leg and will not move during compression of the fork.



WARNING: Tighten the brake calipers to the brake manufacturer's torque specifications.

1.3 Wheels

Consult the technical specifications provided by the wheel manufacturer to install and secure the wheels to the forks.

1.4 Lubricants

Only use hydraulic oil, lubricant and grease included in the kit sold by FORMULA. Hydraulic oil Idemitsu OJ01, Formula FX and Grease Formula Fork Seal. In the cartridge, use hydraulic oil Idemitsu OJ01 only. For lubrication of legs and tubes, use Formula FX only.



CAUTION: Do not use lubricants other than those recommended above. Use of other lubricants may damage the fork and make it unsafe.

Threadlocker for screws

Apply a liberal amount (where indicated) of medium strength threadlocker all the way around the thread. After applying, clean any excess threadlocker with a cloth. Let dry at least 24 hours before installing.



WARNING: The threadlocker used for assembly is dangerous to skin and eyes. Consult and adhere to the warnings on the threadlocker container before use.

2 INSTALLATION

⚠ WARNING: Installation of NERO suspension forks requires specific knowledge, equipment and expertise. General mechanical skills are not sufficient to correctly install the NERO suspension forks.

FORMULA strongly recommends that a qualified service center authorized by FORMULA install the fork on your bicycle. Improperly installed forks can cause damage to the NERO suspension and serious injury or death.

-FORMULA does not authorize the end user to install the fork on the bike.

⚠ WARNING: Failure to follow these guidelines may result in serious injury or death.

2.1 Installing the hose clamp

- Secure the disc brake hose to the fork with clamp (8).
- Loosen the screw (9) and move the clamp over the hose (8).
- Insert the hose inside the hose clamp (8).
- Tighten to 2/3 Nm.

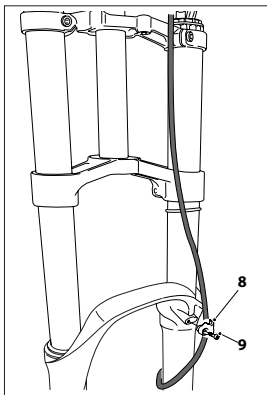

3 USE

⚠ GENERAL SAFETY NOTE: Do not keep the fork fully at the end of the race for a period exceeding 10 days.

If that happens you can verify that the hydraulic system is not working properly.

3.1 Suspension Adjustments

- Use the rebound adjuster (10) to adjust how quickly the fork returns to its extended position after being compressed.
- Correctly setting the rebound speed allows the bicycle to properly track the terrain.
- Rebound that is set too fast will cause the fork to feel springy and uncontrolled and exhibit excessive return speed
- Rebound that is set too slow will not allow the fork to extend quickly enough to prepare for the next bump.
- Turning the adjuster (10) clockwise (toward the + sign) adds hydraulic damping and slows the rebound speed.
- Turning the adjuster (10) counter-clockwise (toward the - sign) removes hydraulic damping and speeds up the fork rebound speed.

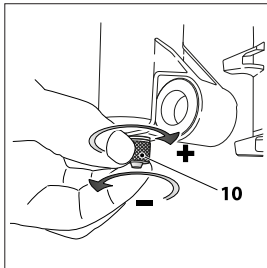

3.2 Adjusting hydraulic compression

- The knob (11) is used to progressively adjust hydraulic compression in high speeds.
- The knob (25) is used to progressively adjust hydraulic compression in low speeds.

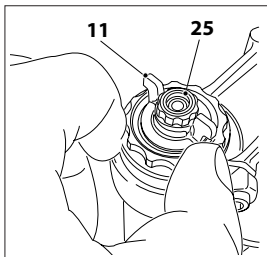

3.3 Spring adjustment

The NERO C fork allows the adjustment of the spring preload from the outside.

When the ring nut (11) is completely loose (anti-clockwise) the spring is at its minimum preload and therefore the fork is softer.

To increase the preload and therefore also the hardness of the fork, turn the ring nut (11) clockwise.

The preload ring nut allows a fine adjustment of the setting.

If you want to substantially change the elastic constant and hardness of the fork, the spring must be replaced.

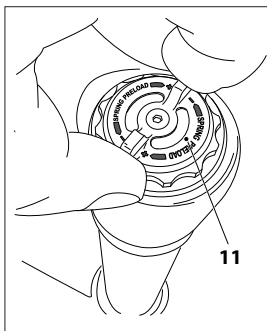

3.4 Spring replacement

Open the plug (12) with the appropriate **SB-A056-01** key.

Remove the spacers and the spring and insert the new spring.

For NERO C forks, the plug (12) must be tightened with a force of **20 to 25 Nm**.

⚠ ATTENTION: To unscrew the cap (12) of the NERO C fork, the screw (13) of the plate must be loosened

The total length of the spring plus spacers (16) is shown in the figure.

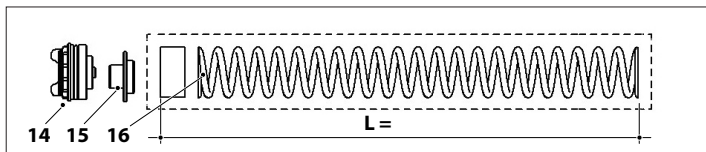
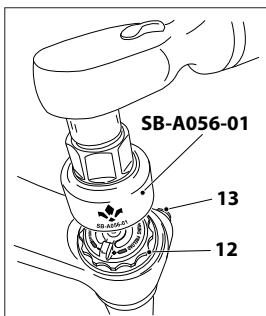

To keep the preload adjustment active, there must always be the spring pusher (15) under the plug.

	L =
Nero	460 mm

NOTE: Before installing the spring check that the shrink insulators (17) are positioned approximately **60mm** from each other..

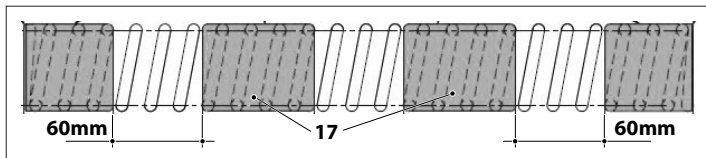

If not, reposition them by screwing them along the spring and once in place, heat them with a jet of hot air.

Gradually heat them until they adhere well to the surface of the coils.

⚠ WARNING: Do not bring the jet of hot air too close to the shrink insulator so as not to damage it.

⚠ WARNING: danger of burns, touch the parts only after they have cooled down.

4 MAINTENANCE

MAINTENANCE INTERVAL TABLE

Comply with the following maintenance intervals in order to preserve the functionality and performance of your FORMULA fork..

WARNING: In case of frequent use of the fork under extreme stresses, maintenance operations will have to be carried out more frequently, based on the actual use conditions.

(*) Do not use high-pressure water

() Do not use solvents or degreasing products that may damage fork components**

Procedure	First Use	Every Ride/ Competition	Every 30 Hours/ 6 Months	Every 100 Hours /1 Year
External cleaning with water and neutral detergent (*)(**)		×		
Internal fork leg cleaning - oil seal and bushing wear check			×	
Hydraulic oil cartridge replacement				×
Air spring maintenance				×

Use genuine spare parts and lubricants recommended by FORMULA.

Wheel axle cleaning

- The wheel axle (**10**) must be disassembled every time you go out and when you wash the bike, it should be dried well and lubricated if needed.
- If the wheel axle (**10**) does not dry after washing the bike and it is left mounted for a long time, the aluminum of the axle and the magnesium of the leg will oxidize.
- First unscrew the lock nut (**5**) and then the pin (**10**).
- After assembly, tighten the pin with a tightening torque of 18Nm, as indicated in the pin

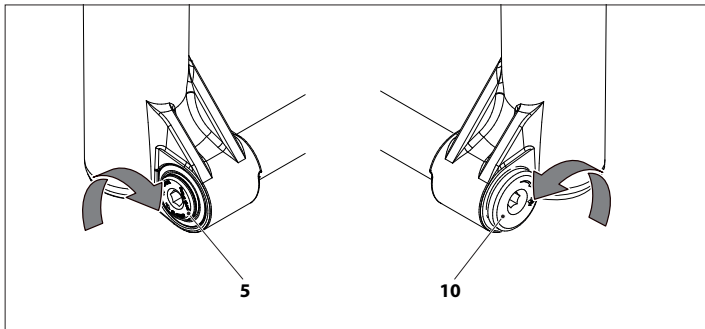

4.2 Issues - Causes - Remedies

This chart mentions some issues that may be encountered when using the fork along with the possible causes and remedies.



WARNING: The operations listed below and accompanied by this symbol must be carried out only by authorized service centers.

Fork not using full travel	The spring is too hard.	Reduce the spring preload or if necessary put a softer spring (🔧).
Fork extends too quickly, violent rebound after bumps	Rebound damping insufficient	Increase rebound damping
Steerer tends to "close" when turning	Excessive rebound damping	Decrease rebound damping
Fork slow during extension or "packs-up" over multiple bumps	Excessive rebound damping	Decrease rebound damping
Bump noise during return but without violent rebound	Excessive rebound damping	Decrease rebound damping
Dust seal leaks oil	Dust seal damaged	(🔧) Replace dust seal
Large amount of oil on upper tubes or oil leaks from bottom of fork	Seals damaged, uppers may be damaged	(🔧) Replace all seals and have uppers inspected
Fork "sticky", does not work like new	Seals dirty, fork requires maintenance	(🔧) Replace all seals
Oil loss from bottom of fork	Bottom nut/screw loose O-ring damaged	Tighten the nut or screw (🔧) Replace O-ring
Loss of sensitivity	Slide bushings worn Oil old	(🔧) Replace slide bushings (🔧) Change oil

 **WARNING: If the fork ever loses oil, do not use the bike. Find and repair any oil losses before using the bike again.**

 **WARNING: Seals and upper tubes should be kept clean to avoid damage to fork seals and upper tubes.**

 **WARNING: If the fork sags, immediately adjust compression or the pressure of the chambers. Incorrect compression adjustment may cause damage to the fork, serious injury or death.**

READ CAREFULLY!

FORMULA. extends to the original purchaser of its forks a limited warranty that the forks are free of defects in material and/or workmanship for a period of two years from date of purchase.

WHAT PROTECTION DO I RECEIVE FROM THE WARRANTY?

FORMULA. will, at its discretion, repair or replace the defective product under warranty.

WARRANTY CONDITIONS AND LIMITATIONS

1. The manufacturer guarantees its products to be free from defects in materials or workmanship for 24 months from the date of purchase. You must establish proof of purchase with a mandatory document (sales receipt or invoice) showing the date and place of retail purchase of the product in order to obtain warranty service.
2. The validity of this warranty is subject to the following:
 - (a)-The claim must be initiated within eight (8) days of discovery of the potential defect;
 - (b)- Every claim must be submitted to the FORMULA. dealer from which the product was purchased, with the understanding, however, that the discretion as to the acceptability of the claim is exclusively FORMULA's ;
 - (c)-Only a FORMULA. Dealer can ship the allegedly defective product, with the accompanying documentation.

Failure to comply with these procedures will invalidate the claim; in which case the product will be made available to the owner for thirty (30) days and then destroyed.

3. This warranty does not cover damages resulting from:
- a. Incorrect transport and installation. Incorrect installation refers to failure to follow the safety guidelines and instructions outlined in the Instructions manual.**
 - b. Unintended and inappropriate use of the product. Unintended and inappropriate use refers to use of the product for purposes different from those for which it was specifically designed and manufactured. Some unintended purposes include cross country and UCI sanctioned downhill races.**
 - c. Use of materials or spare parts that do not carry the FORMULA trademark NERO forks. FORMULA shall not guarantee conformity, safety, service life and performance of FORMULA NERO forks if materials and spare parts that do not carry the FORMULA trademark and/or are non-compatible and/or are not suitable and/or are not expressly authorized are used.**
 - d. Lack of appropriate or reasonable maintenance or storage, washing with harsh materials, use of corrosive agents, prolonged exposure to solvents.**
 - e. Products on which the serial number and/or production code have been altered, damaged and/or removed.**
 - f. Modifications made by persons not duly authorized by FORMULA without being approved by FORMULA.**
 - g. Normal wear and tear or deterioration due to the use of the product.**
 - h. The result of rider mishap or crash.**
4. Retailers, wholesalers, importers or anyone else apart from FORMULA. may not modify this warranty in any way.
5. This warranty does not affect the statutory rights of the consumer or any rights the purchaser may have against the dealer pursuant to the sales contract.
6. The laws of Italy govern all matters arising out of or relating to this warranty. Any disputes or legal actions by purchaser arising out of or relating to this warranty shall be brought in court in Prato.



Formula

www.rideformula.com

FORMULA S.a.s. di "Formula Group S.r.l." & C.

Via Erbosa, 63 - 59100 Prato (Italia)

Tel. +39 0574 603 609

Fax +39 0574 611 046

Reg. Imprese Prato / C.F. / P.IVA 02081070977

PEC: formula-italy@legalmail.it

Cap. Soc. 500.000,00 € i.v.

*Information may be enhanced for improvement without prior notice. All rights reserved.
Le informazioni possono essere modificate senza preavviso. Tutti i diritti riservati.*